

# INFORMATION ONLY

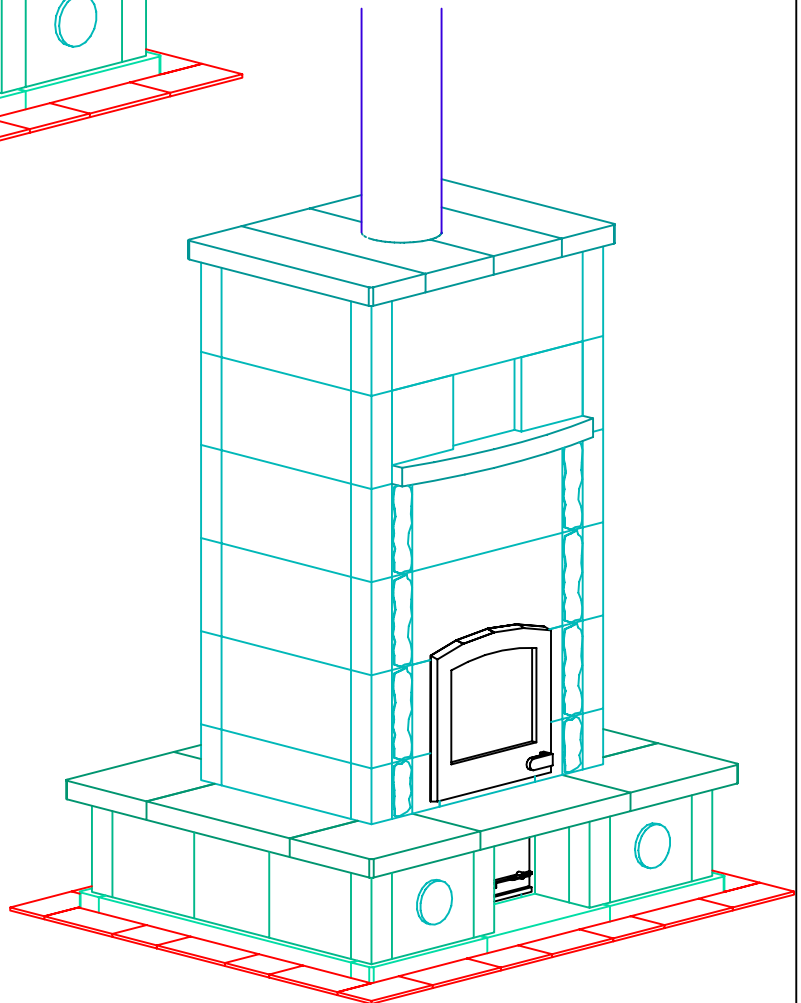

NOTE: Hearth Tiles CUT AND INSTALLED by others

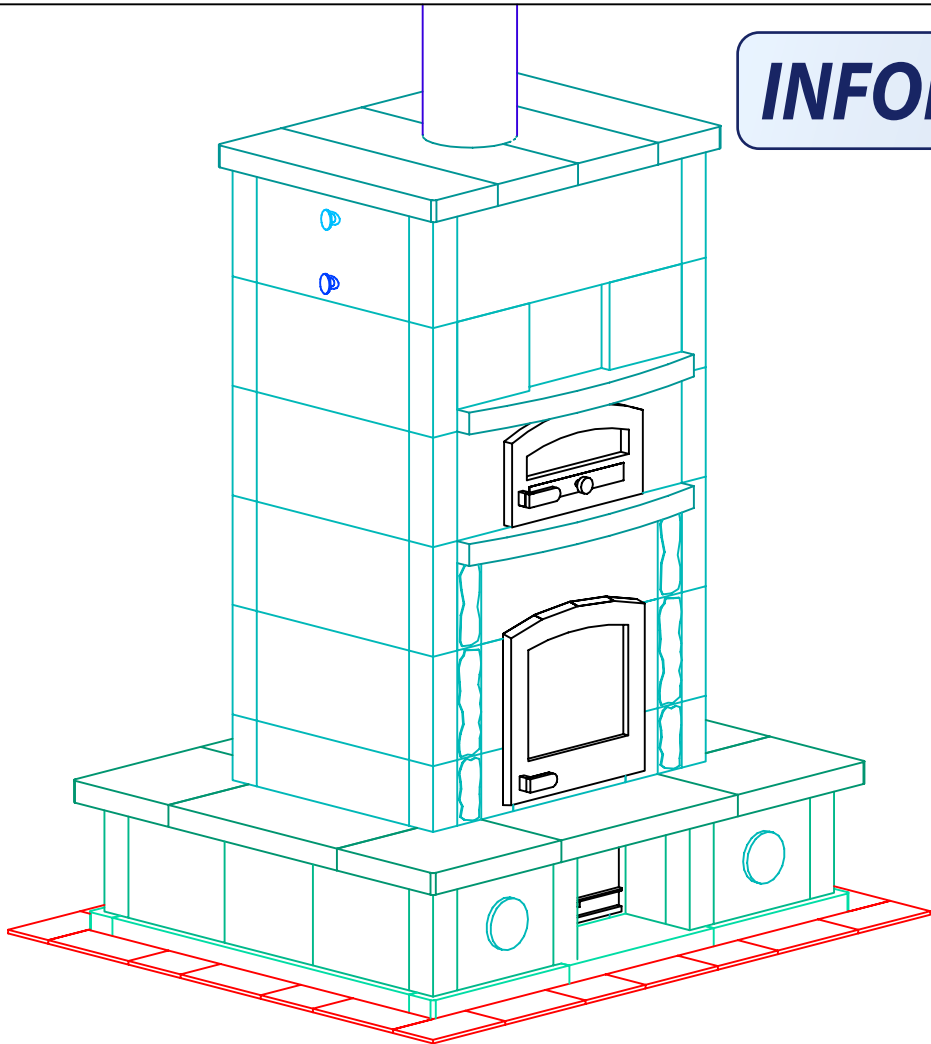

MID-ATLANTIC MASONRY HEAT  
 1229 Harris Street Suite 1  
 Charlottesville, VA 22903  
 (434)979-9709 Fax 434-979-6416

PROJECT TIPLER  
 MODEL TTU2700/5

CONTRACT F5632  
 DRAWN BY G.DIFIORE

VIEW PERSPECTIVE  
 DATE 3/12/04

PAGE 1



SIDE VIEW

# INFORMATION ONLY

8" I.D. \ 10" O.D. Double Wall  
Stainless Steel Flue  
Pipe by others

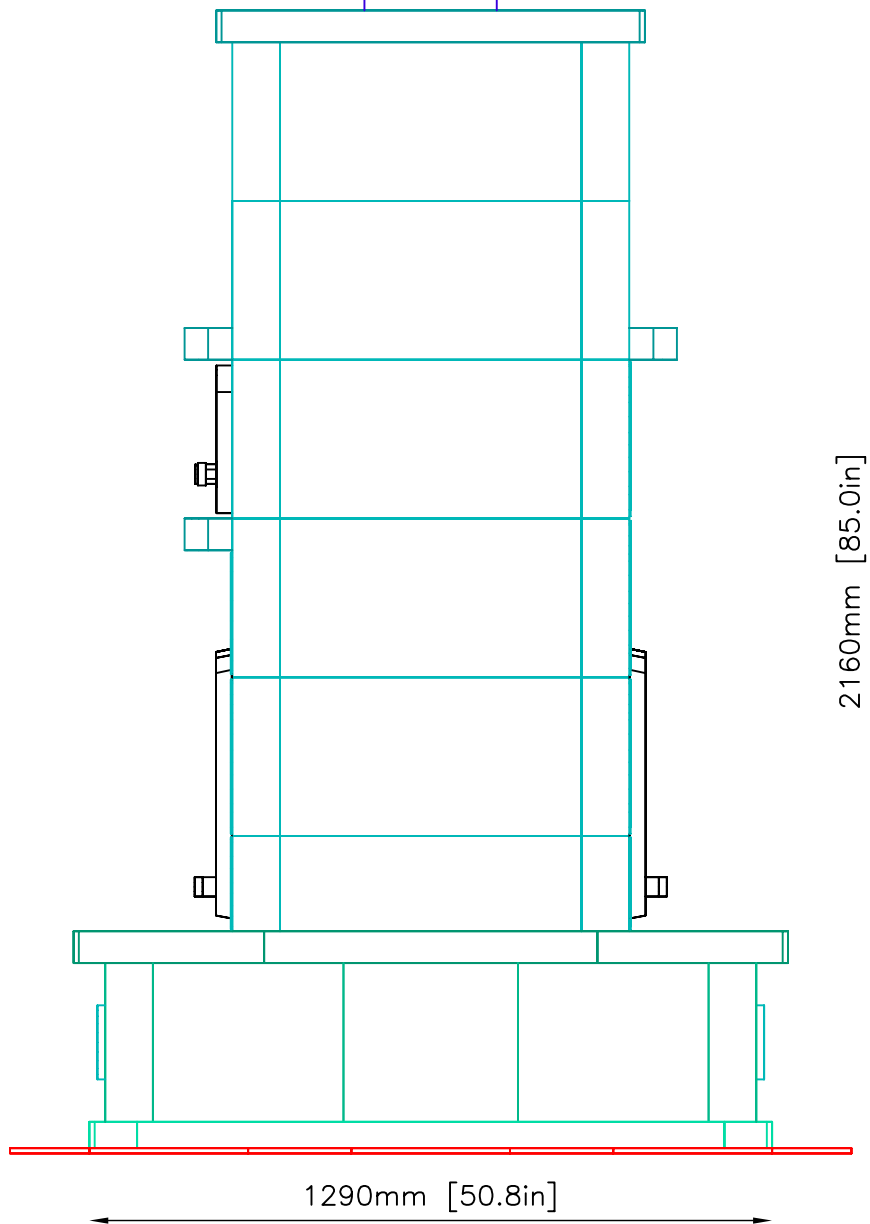

**INFORMATION ONLY**

NOTE: Hearth Tiles CUT AND INSTALLED by others

8" I.D. \ 10" O.D. Double Wall  
Stainless Steel  
Flue Pipe  
by others  
SEE PAGE 5  
FOR FLUE LOCATION

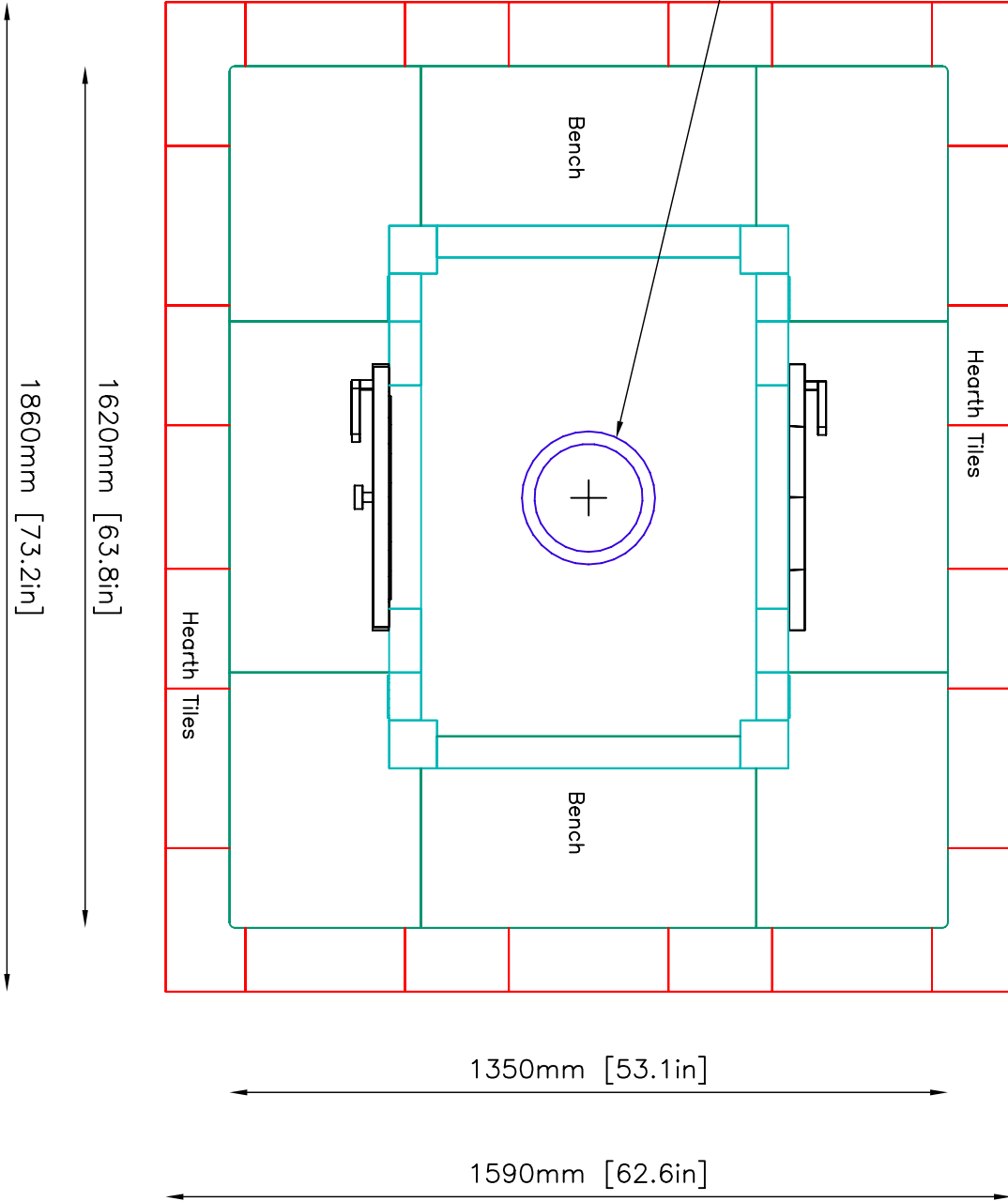

# FOUNDATION SLAB

Minimum 4" Thick Poured Concrete With Rebar 6"O.C.  
 Minimum Dimensions--2" from Base of Unit

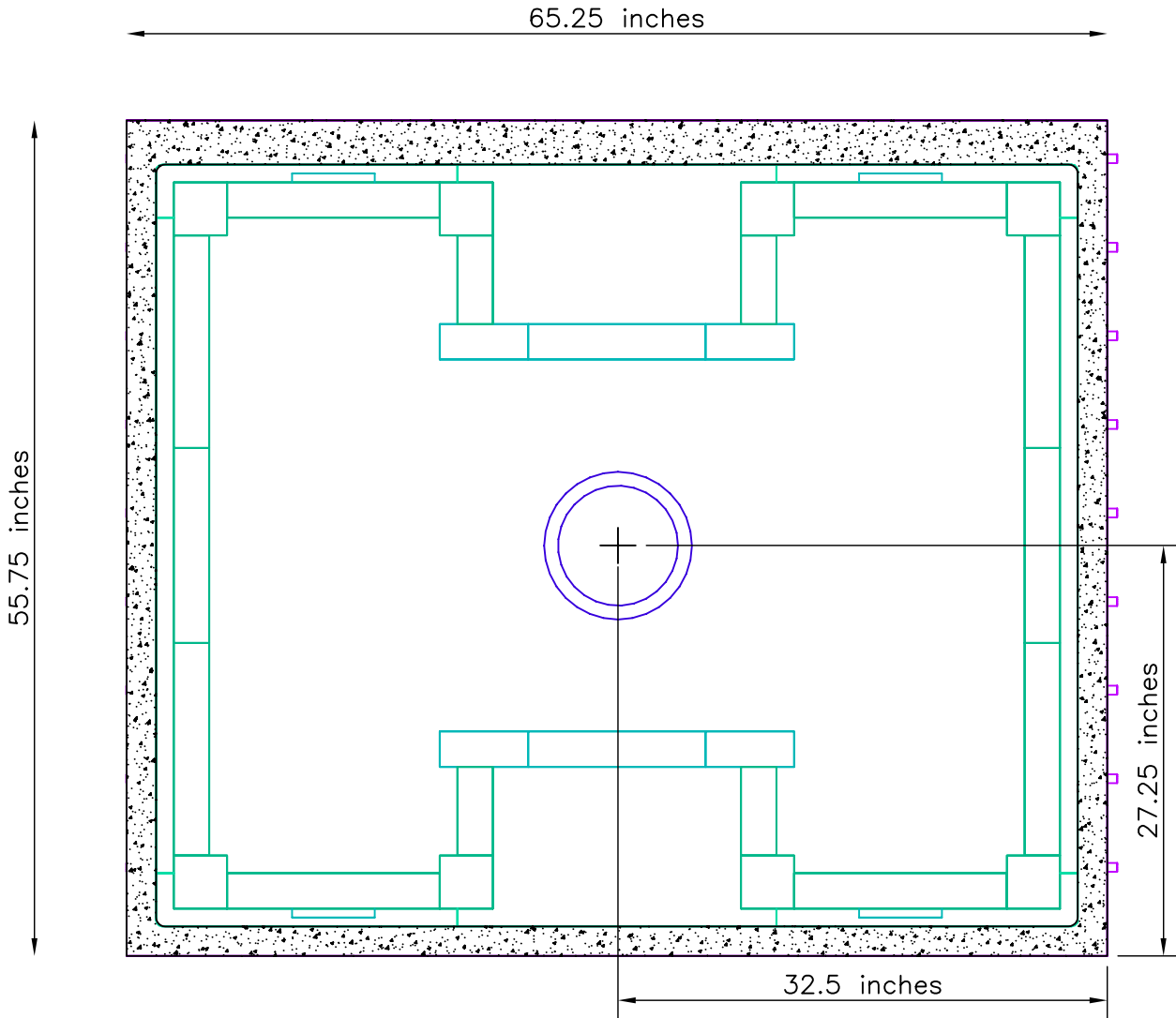

**FLUE LOCATION:**

27¼" x 32½" From Lower Right Corner of Foundation Slab  
 to CENTER of Flue Pipe.

## INFORMATION ONLY

**NOTE:**

TOP OF FOUNDATION SLAB TO BE LEVEL AND FLUSH WITH SUB-FLOOR

- Tolerances: +/- 1/8" No additional cost to level slab
- +/- 1/4" \$150.00-\$200.00 additional cost to level slab
- +/- 1/2" \$500.00 additional cost to level slab

UNIT WEIGHT: 10,000lbs.

Owner/Contractor is responsible for engineering Foundation Slab to support weight of fireplace.



MID-ATLANTIC MASONRY HEAT  
 1229 Harris Street Suite 1  
 Charlottesville, VA 22903  
 (434)979-9709 Fax 434-979-6416

PROJECT TIPLER  
 MODEL TTU2700/5

CONTRACT F5632  
 DRAWN BY G.DIFIORE

VIEW SUPPORT  
 DATE 3/12/04

PAGE 5

FOUNDATION SLAB:  
 \* MINIMUM 4" THICK  
 WITH REBAR 6" O.C.  
 \* NON-COMBUSTIBLE  
 CEMENT BOARD  
 under foundation slab  
 (NOT PLYWOOD)

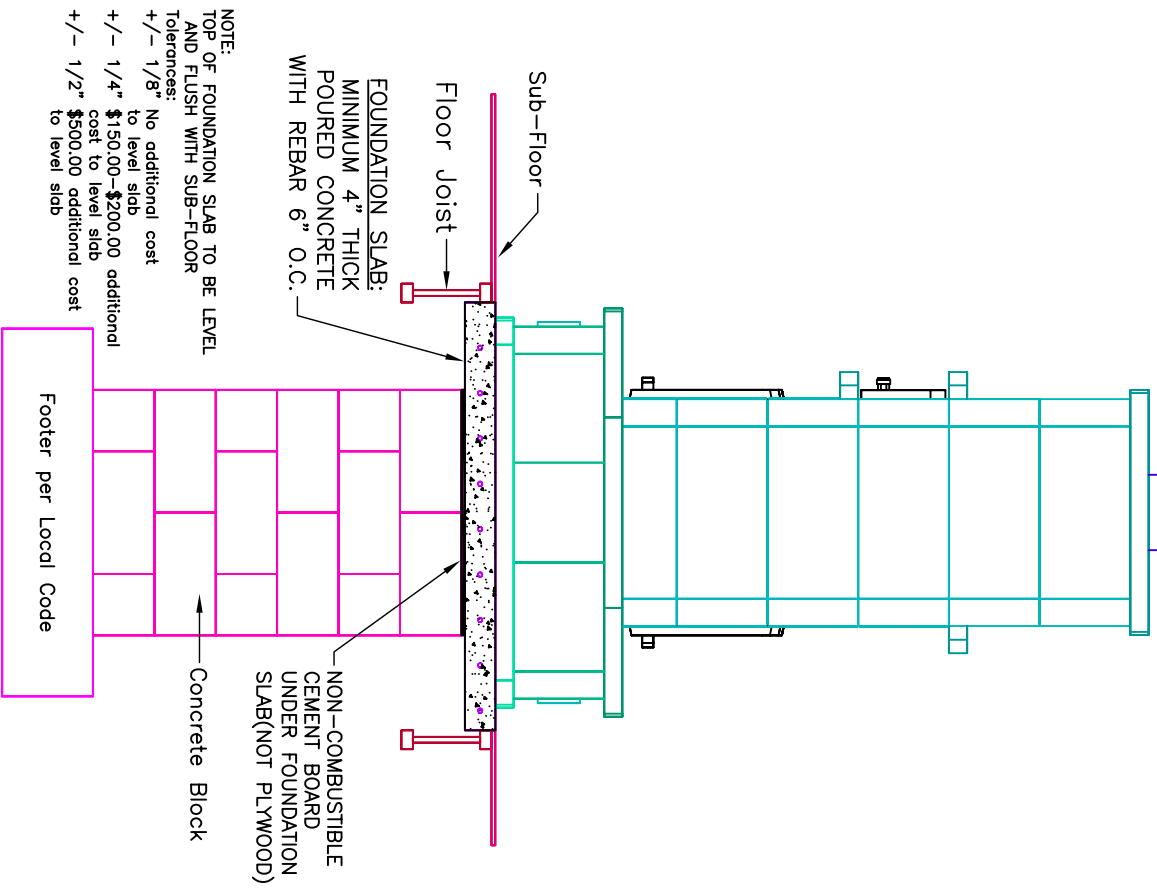

NOTE:  
 TOP OF FOUNDATION SLAB TO BE LEVEL  
 AND FLUSH WITH SUB-FLOOR  
 Tolerances:  
 +/- 1/8" No additional cost  
 to level slab  
 +/- 1/4" \$150.00-\$200.00 additional  
 cost to level slab  
 +/- 1/2" \$500.00 additional cost  
 to level slab

UNIT WEIGHT: 10,000lbs.  
 Owner/Contractor is responsible for engineering Foundation Slab to support weight of fireplace.

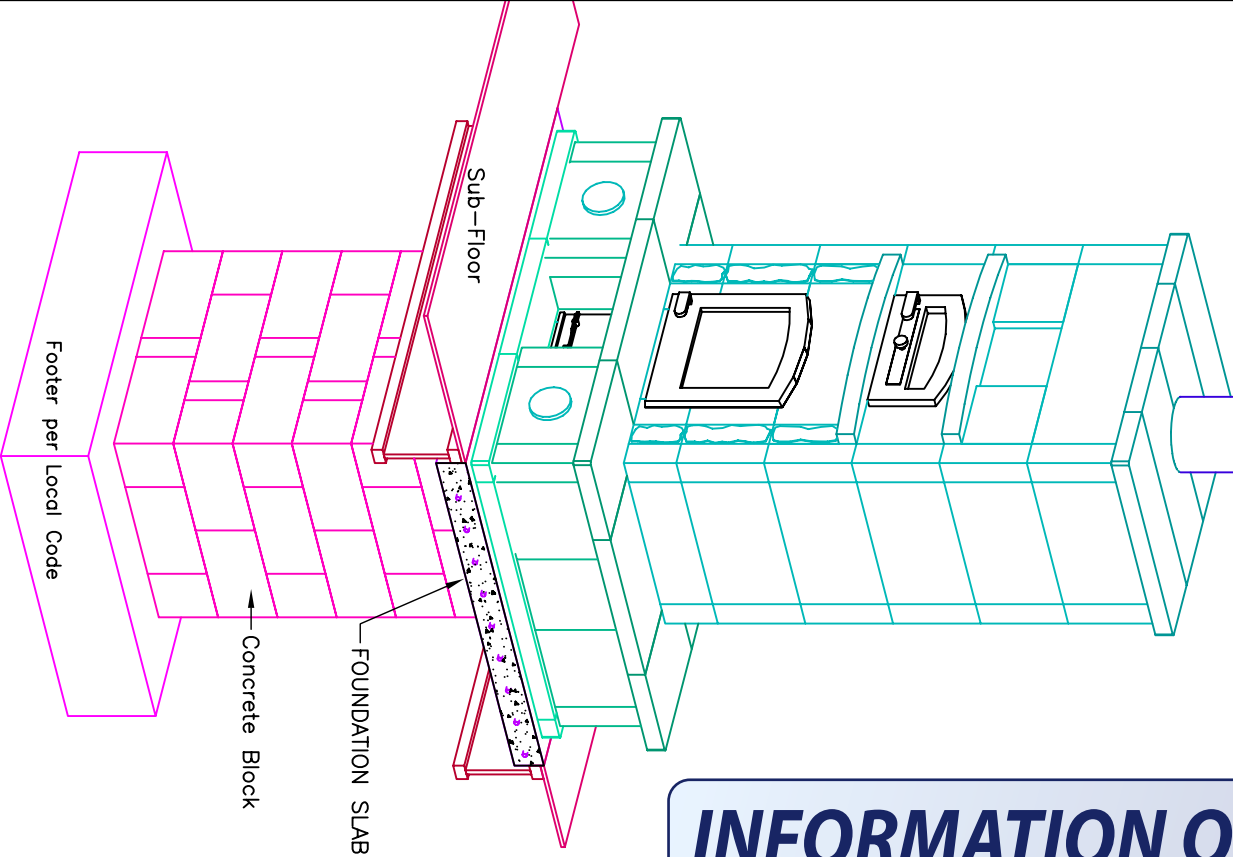

**INFORMATION ONLY**



MID-ATLANTIC MASONRY HEAT  
 McIntire Business Park  
 Charlottesville, VA 22903  
 (434)979-9709 Fax 434-979-6416

PROJECT TIPLER	CONTRACT F5632	VIEW Foundation Slab	PAGE 6
MODEL TTU2700/5	DRAWN BY G.DIFIORE	DATE 3/12/04	