

INFORMATION ONLY

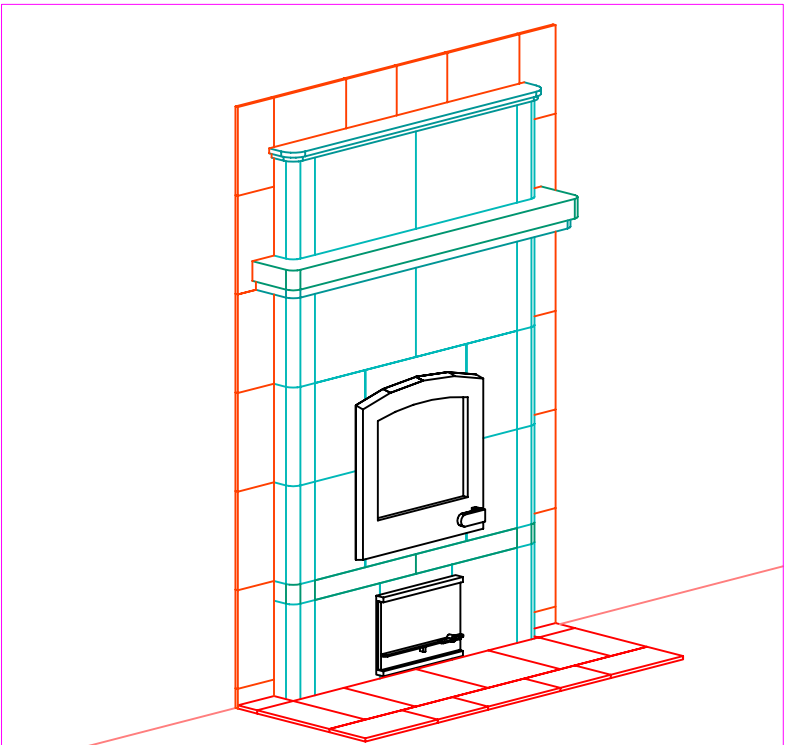

NOTE:
Hearth & Wall Tiles CUT AND INSTALLED
by others

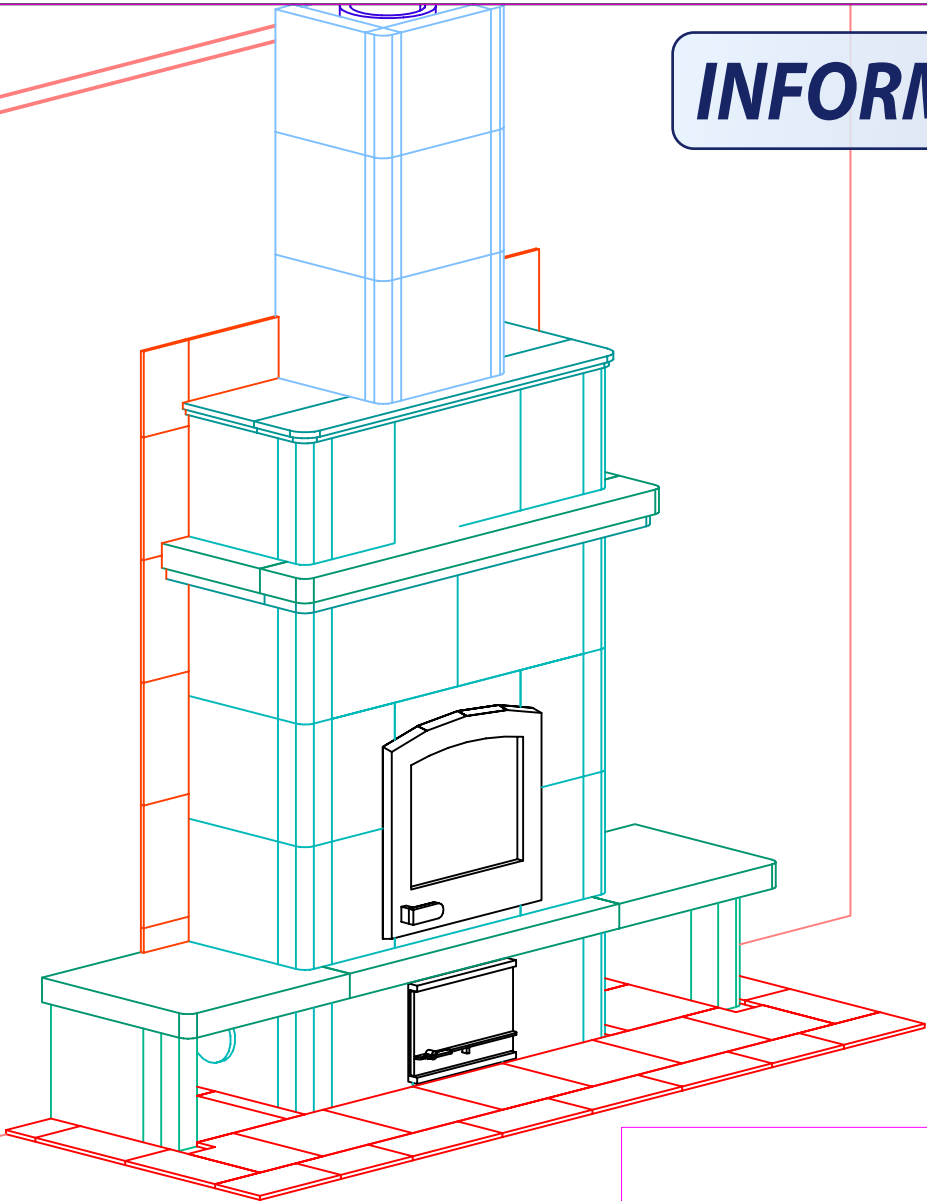

MID-ATLANTIC MASONRY HEAT
1229 Harris Street Suite 1
Charlottesville, VA 22903
(434)979-9709 Fax 434-979-6416

PROJECT LONGMIRE
MODEL TU2200

CONTRACT
DRAWN BY D.P.BYRAM

VIEW PERSPECTIVE
DATE 10/29/03

PAGE 1

FRONT VIEW

INFORMATION ONLY

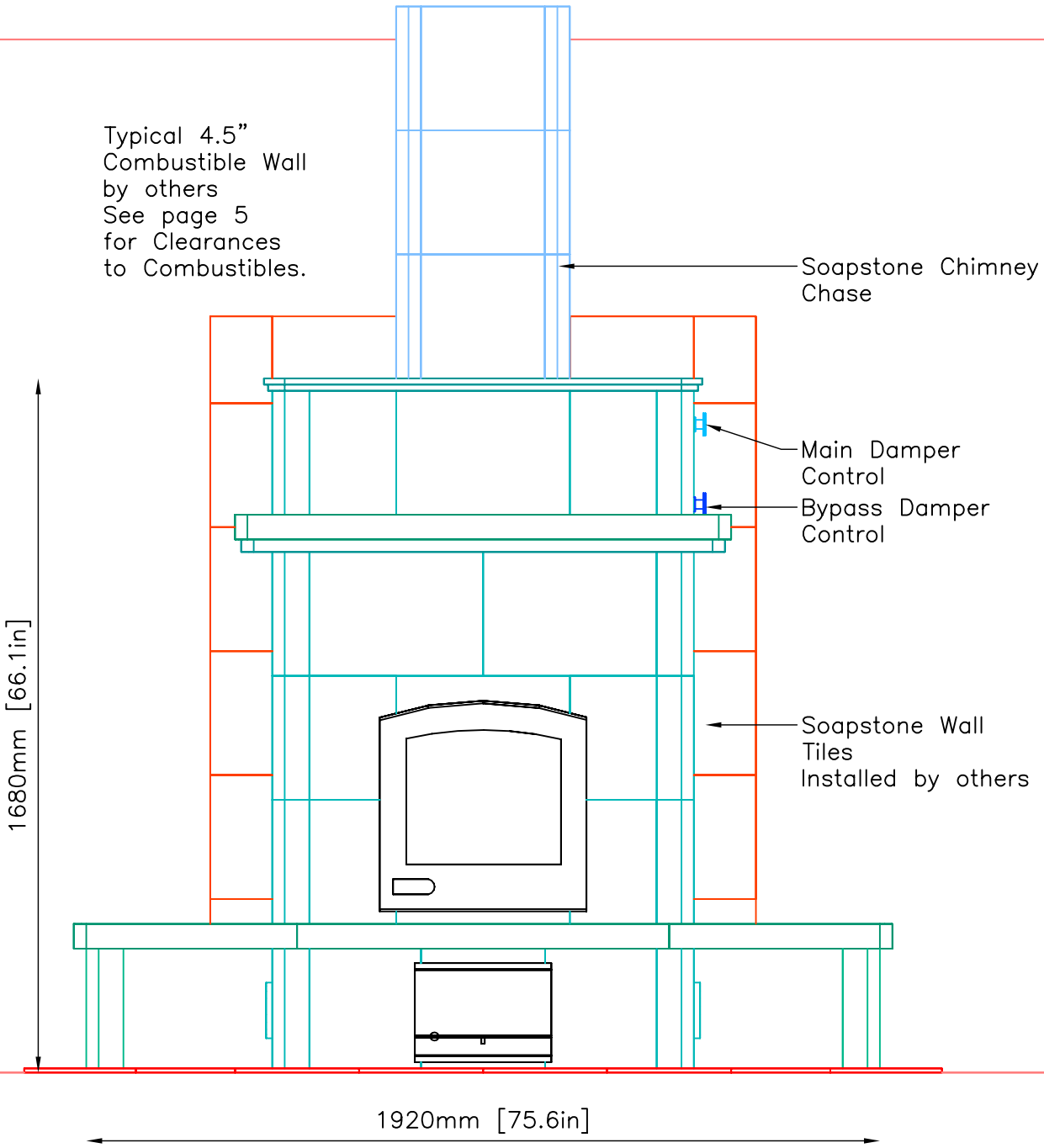

NOTE: Hearth & Wall Tiles CUT AND INSTALLED by others



MID-ATLANTIC MASONRY HEAT
 1229 Harris Street Suite 1
 Charlottesville, VA 22903
 (434)979-9709 Fax 434-979-6416

PROJECT LONGMIRE
 MODEL TU2200

CONTRACT
 DRAWN BY D.P.BYRAM

VIEW FRONT
 DATE 10/29/03

PAGE 2

BACK VIEW

INFORMATION ONLY

Typical 4.5”
Combustible Wall
by others
See page 5
for Clearances
to Combustibles.

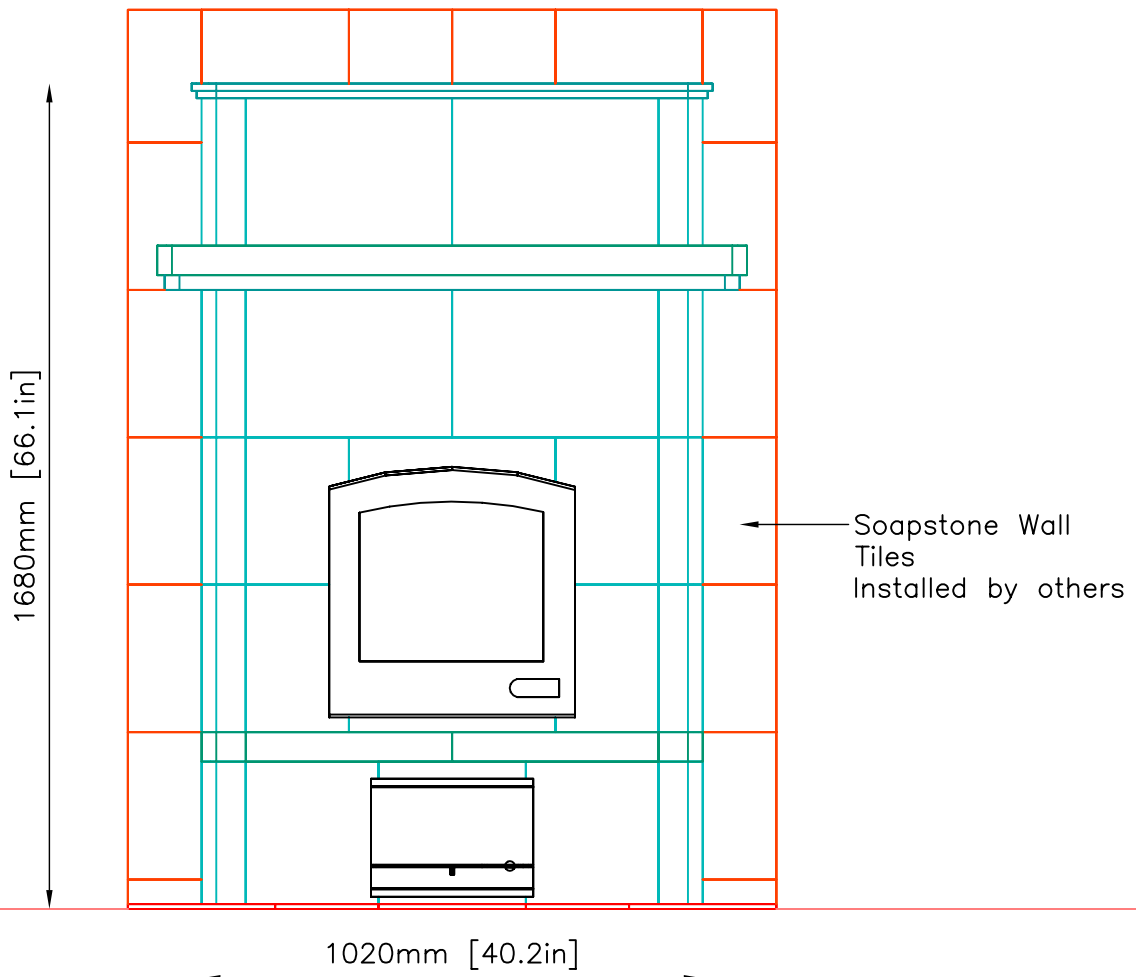

NOTE: Hearth & Wall Tiles CUT AND INSTALLED by others



MID-ATLANTIC MASONRY HEAT
1229 Harris Street Suite 1
Charlottesville, VA 22903
(434)979-9709 Fax 434-979-6416

PROJECT LONGMIRE
MODEL TU2200

CONTRACT
DRAWN BY D.P.BYRAM

VIEW BACK
DATE 10/29/03

PAGE 3

SIDE VIEW

INFORMATION ONLY

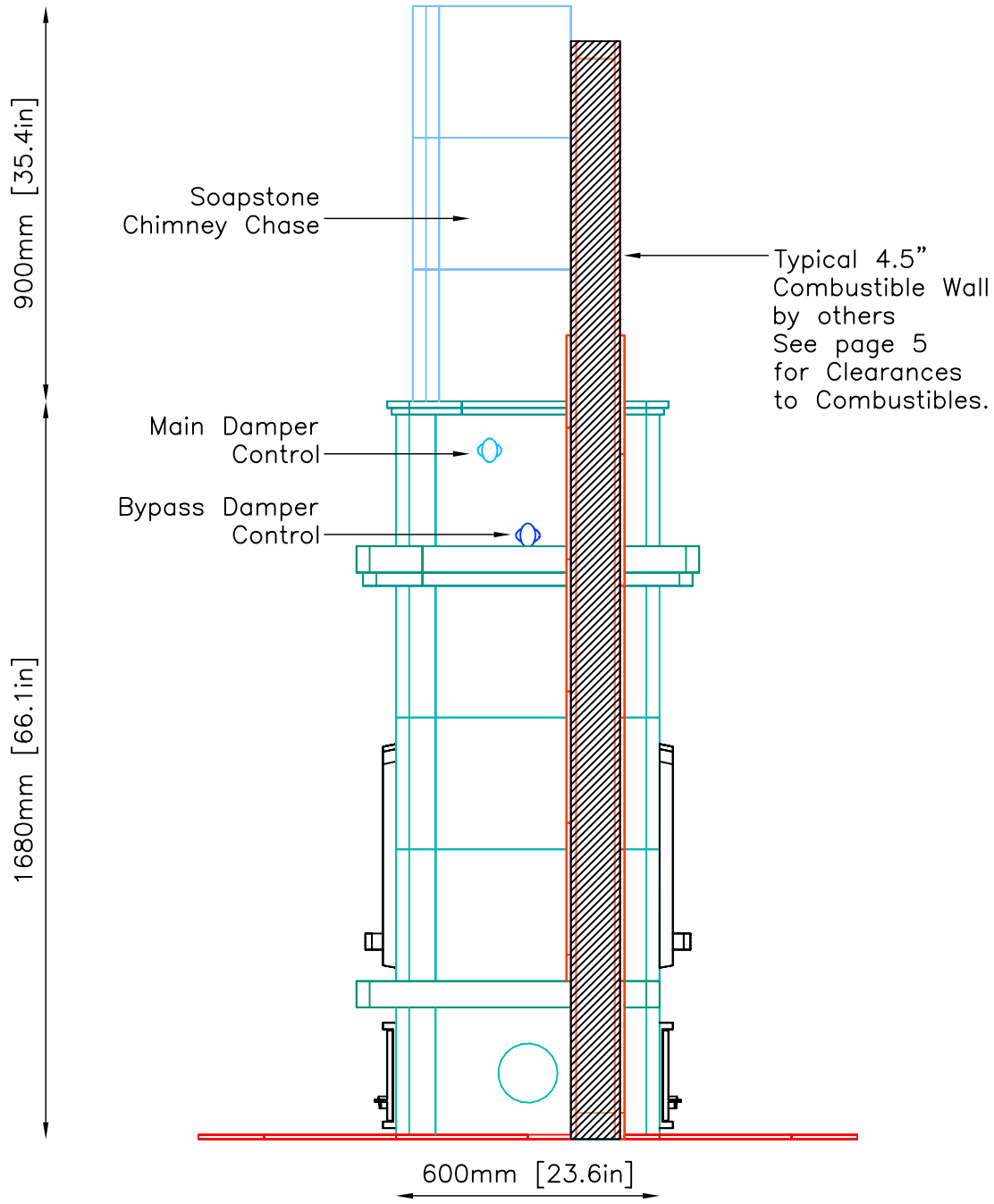

NOTE: Hearth & Wall Tiles CUT AND INSTALLED by others

INFORMATION ONLY

PLAN VIEW

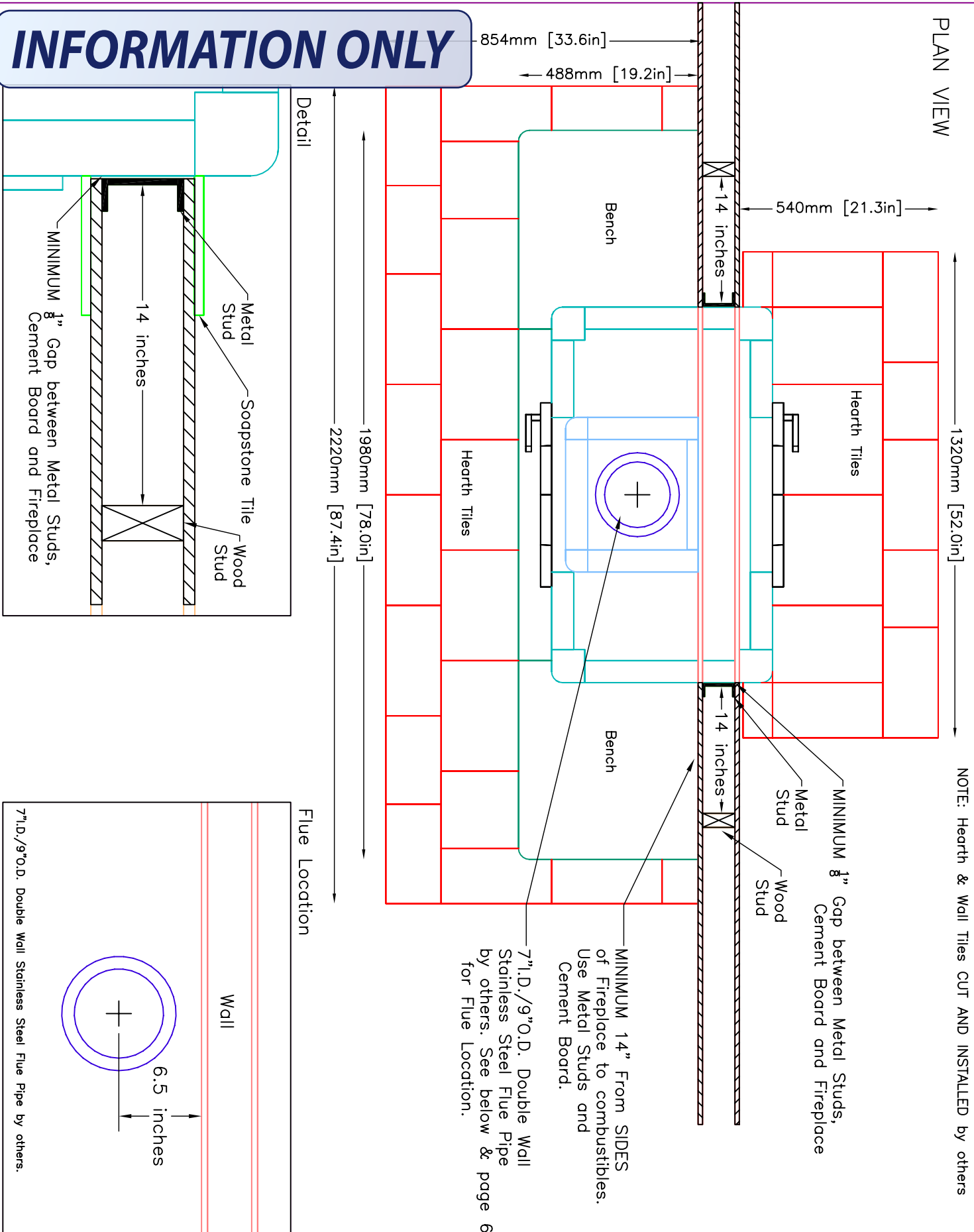

	MID-ATLANTIC MASONRY HEAT 1229 Harris Street Suite 1 Charlottesville, VA 22903 (434)979-9709 Fax 434-979-6416	PROJECT	CONTRACT	VIEW	PAGE
		LONGMIRE		PLAN	
		MODEL	DRAWN BY	DATE	
		TU2200	D.P.BYRAM	10/29/03	5

FOUNDATION SLAB

Minimum 4" Thick Poured Concrete With Rebar 6" O.C.
 Minimum Dimensions—2" from Base of Unit

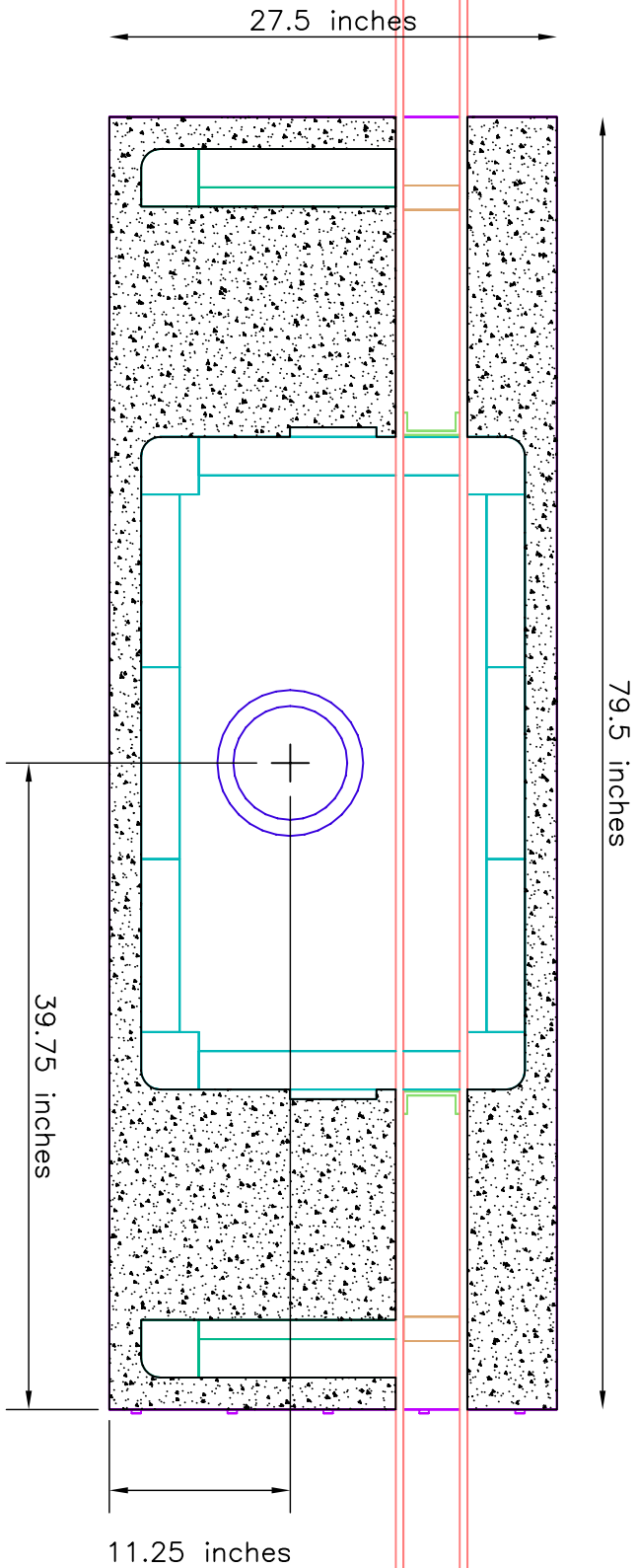

FLUE LOCATION:
 From Lower Right Corner of Foundation Slab:
 1 1/4" x 39 3/4" to CENTER of Flue Pipe.

NOTE:
 TOP OF FOUNDATION SLAB TO BE LEVEL AND FLUSH WITH SUB-FLOOR

Tolerances: +/- 1/8" No additional cost to level slab
 +/- 1/4" \$150.00—\$200.00 additional cost to level slab
 +/- 1/2" \$500.00 additional cost to level slab

UNIT WEIGHT: 5,000 lbs.

Owner/Contractor is responsible for engineering Foundation Slab to support weight of fireplace.

INFORMATION ONLY



MID-ATLANTIC MASONRY HEAT
 1229 Harris Street Suite 1
 Charlottesville, VA 22903
 (434)979-9709 Fax 434-979-6416

PROJECT LONGMIRE
 MODEL TU2200

CONTRACT
 DRAWN BY D.P.BYRAM

VIEW SUPPORT
 DATE 10/29/03

PAGE 6

FOUNDATION SLAB:
 * MINIMUM 4" THICK
 WITH REBAR 6" O.C.
 * NONCOMBUSTIBLE
 CEMENT BOARD
 under foundation slab
 (NOT PLYWOOD)

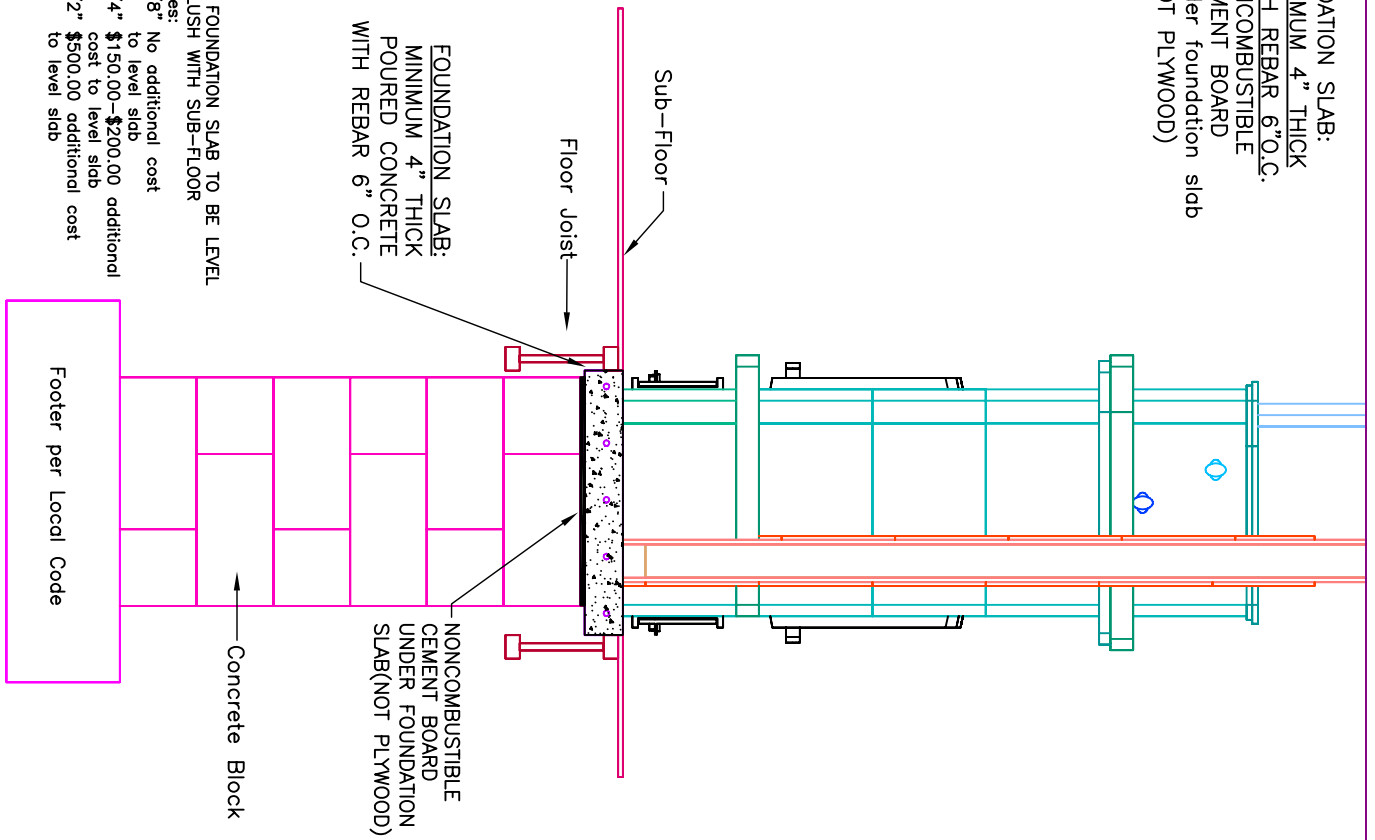

FOUNDATION SLAB:
 MINIMUM 4" THICK
 POURED CONCRETE
 WITH REBAR 6" O.C.

NONCOMBUSTIBLE
 CEMENT BOARD
 UNDER FOUNDATION
 SLAB (NOT PLYWOOD)

NOTE:
 TOP OF FOUNDATION SLAB TO BE LEVEL
 AND FLUSH WITH SUB-FLOOR
 Tolerances:
 +/- 1/8" No additional cost
 to level slab
 +/- 1/4" \$150.00-\$200.00 additional
 cost to level slab
 +/- 1/2" \$500.00 additional cost
 to level slab

Footer per Local Code

Concrete Block

UNIT WEIGHT: 5,000 lbs.

Owner/Contractor is responsible for engineering Foundation Slab to support weight of fireplace.

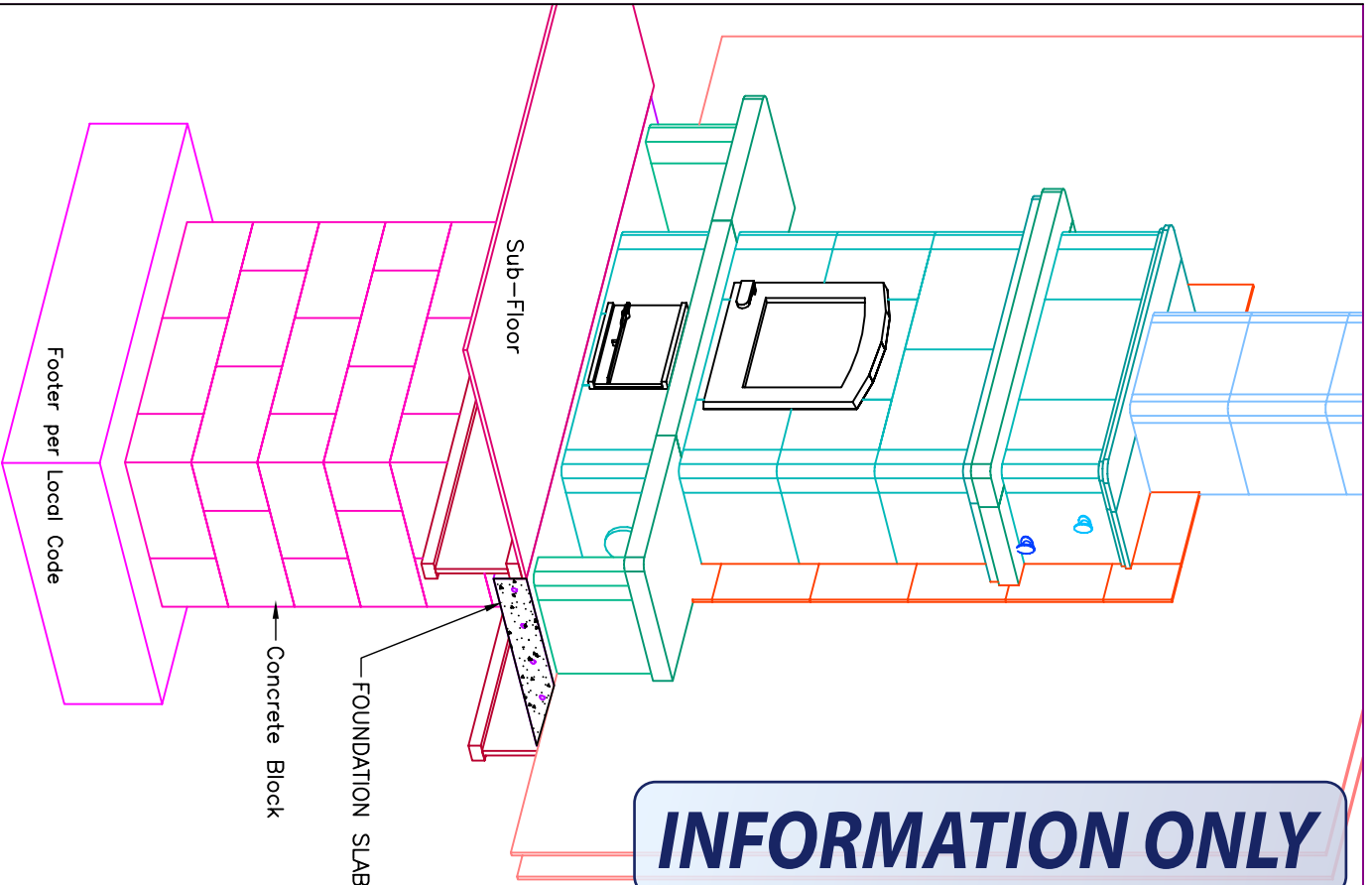

INFORMATION ONLY

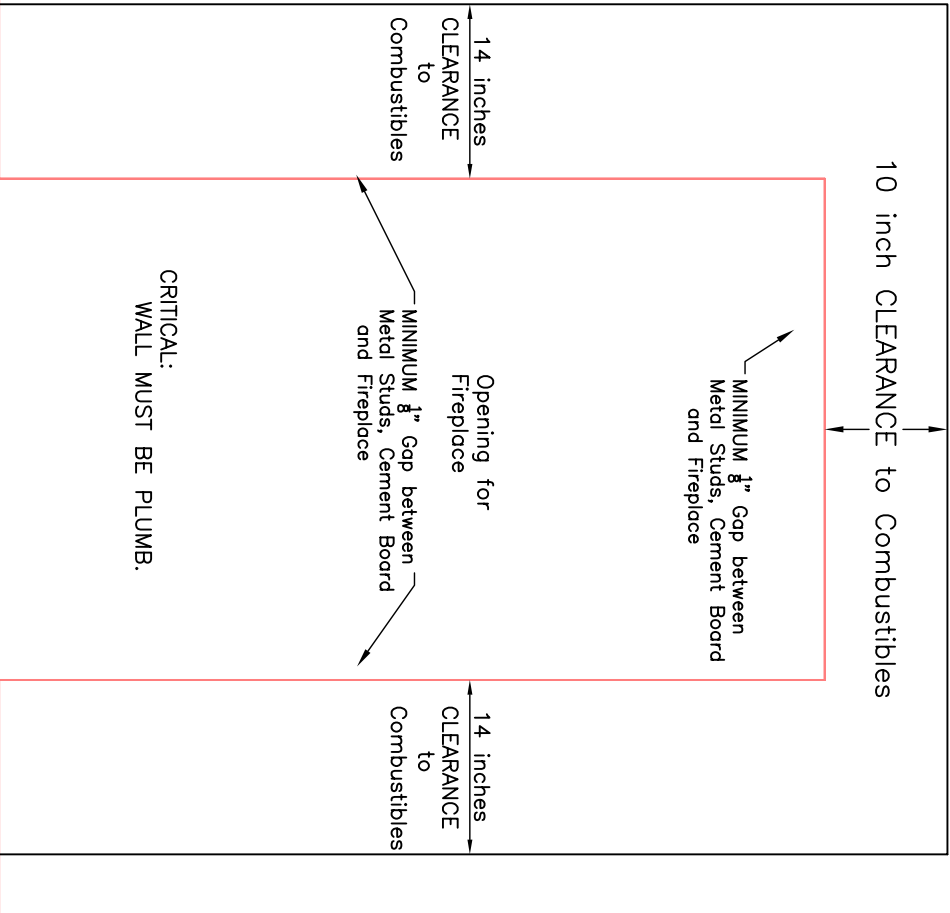

Clearances to Combustible Materials:
 MINIMUM 10" Clearance to Combustible Material from TOP of Fireplace.
 MINIMUM 14" Clearance to Combustible Material from SIDES of Fireplace.
 Use Metal Studs and Cement Board.

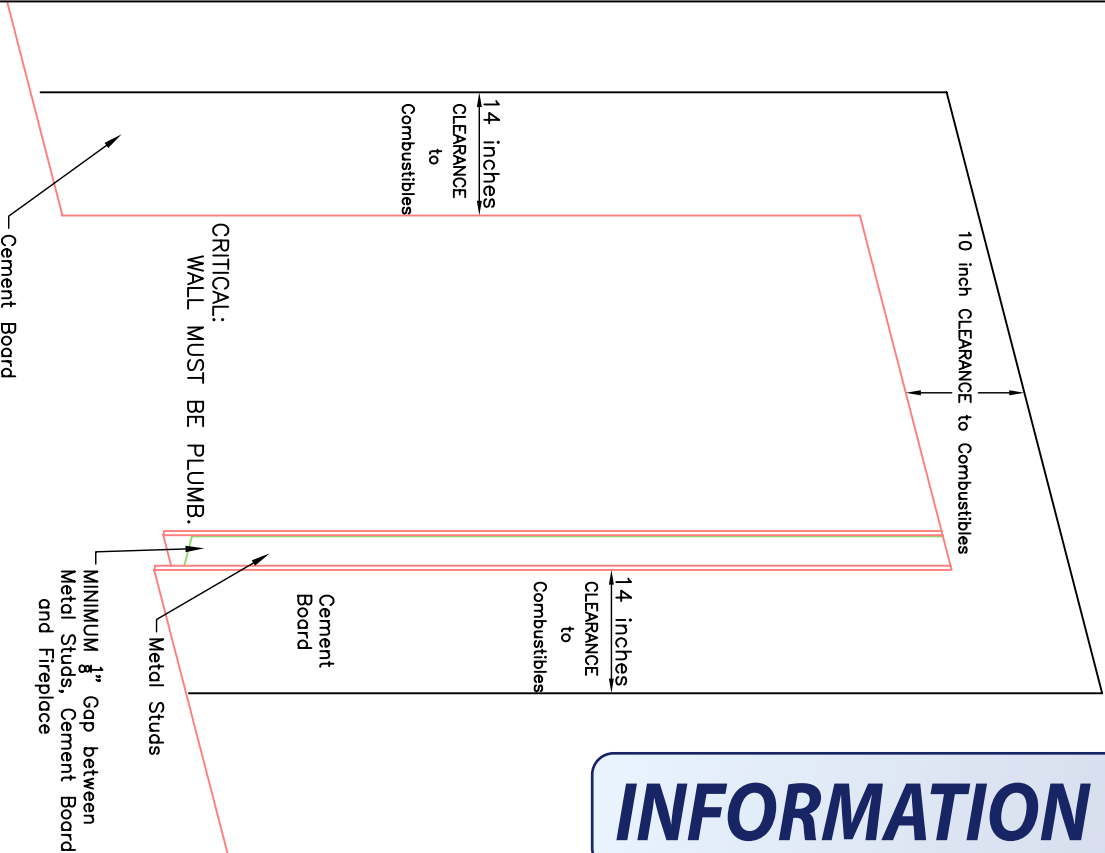

INFORMATION ONLY



MID-ATLANTIC MASONRY HEAT
 1229 Harris Street Suite 1
 Charlottesville, VA 22903
 (434)979-9709 Fax 434-979-6416

PROJECT LONGMIRE
 MODEL TU2200

CONTRACT
 DRAWN BY D.P.BYRAM

VIEW Wall Detail
 DATE 10/29/03

PAGE 8